



AIR ZONE INDUSTRIES, INC.

Series: CFS
Cabinet Fan Section

SUBMITTAL DATA

SLIP ON
OUTLET

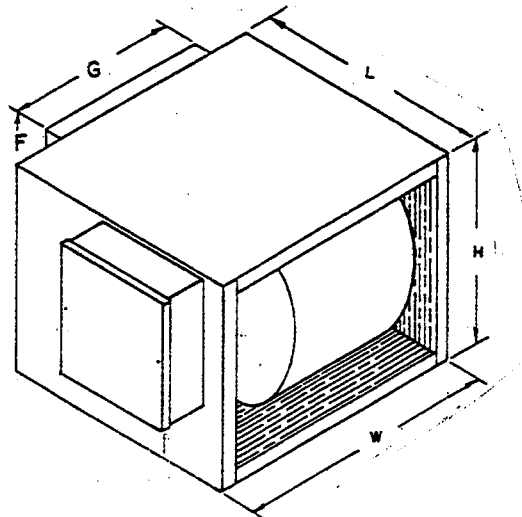

CONTROL BOX

R.A. FILTER

BOTTOM ACCESS DOOR

SPECIFICATIONS

CASING - Minimum 22 gauge galvanized steel reinforced for maximum rigidity and sealed for minimum leakage (less than 2% at 3.0" wg). Units are complete with 1" - 1 1/2# density internal liner in accordance with NFPA-90A (see option below for Hospital Liner). A full bottom removable access door is standard for complete service to all internal components. See options below for electric, hot water or steam heat.

MOTOR & BLOWERS - Direct drive, forward curved, multiblade centrifugal blowers are complete with resilient mounted, multi speed, PSC, thermally protected, high efficient motors with shutter at fan discharge.

QTY	MODEL	MAX	DIMENSIONS				
EA.	NO.	CFM	H	W	D	F	G
	CFS-02	200	18	23	23	15	15
	CFS-04	400	18	23	23	15	15
	CFS-06	600	18	23	23	15	15
	CFS-09	900	18	23	23	15	15
	CFS-12	1200	18	23	23	15	15
	CFS-16	1600	18	23	23	15	15
	CFS-20	2000	18	23	23	15	15
	CFS-22	2200	18	23	23	15	15
	CFS-24	2400	18	28	23	15	15

Options:

<input type="checkbox"/> Hospital liner	<input type="checkbox"/> Fan P.E.	<input type="checkbox"/> 3 Speed switch	<input type="checkbox"/> Outlet Volume Control
<input type="checkbox"/> Hot Water Heat	<input type="checkbox"/> Electric Heat	<input type="checkbox"/> H.W. Heat	<input type="checkbox"/> Steam Heat
<input type="checkbox"/> 1" Inlet Filter	<input type="checkbox"/> 2" Inlet Filter	<input type="checkbox"/> S & Drive Out	<input type="checkbox"/> R/A Attenuator
<input type="checkbox"/> Fan Relay	<input type="checkbox"/> 24v - 40 va Transformer	<input type="checkbox"/> Control Cover	

Primary Voltage:

<input type="checkbox"/> 115/1/60	<input type="checkbox"/> 208/220/1/60	<input type="checkbox"/> 277/1/60
-----------------------------------	---------------------------------------	-----------------------------------