

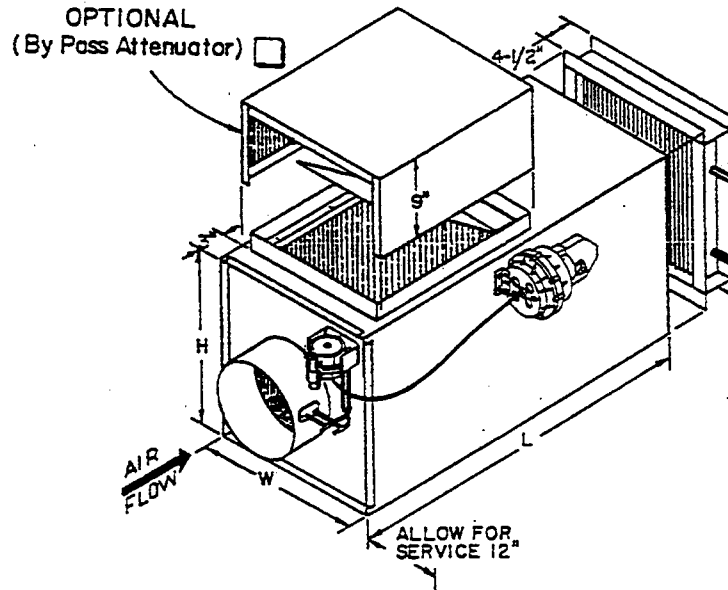

**AIR ZONE INDUSTRIES, INC.**

**SERIES: BPT-W PNEUMATIC**

## SUBMITTAL DATA



### SPECIFICATIONS

**CASING** — Minimum 24 gauge galvanized steel reinforced for maximum rigidity and minimum leakage. Units complete with a minimum of 1/2" - 2# density insulation in accordance with NFPA-90A.

**PRIMARY AIR VALVE** — Constructed of welded steel channel frame with 18 gauge galvanized steel blades, die formed stiffeners and full blade stop. Stainless steel side seals standard along with blade seals to minimize leakage. All hardware is zinc plated with brass pivot points and bronze oilite bearings. Shafts are corrosion resistant 1/2" diameter.

DIMENSIONS						
Qty.	Model	Max. CFM	Inlet Size	W	H	L
	BPT-04-W	200	3-3/4	11	12	24
	BPT-05-W	400	4-3/4	11	12	24
	BPT-06-W	550	5-3/4	11	12	24
	BPT-08-W	1,000	7-3/4	18	12	24
	BPT-10-W	1,600	10-3/4 X 7-3/4 <sup>1</sup>	18	12	24
	BPT-12-W	2,200	13-3/4 X 7-3/4 <sup>1</sup>	18	12	24
	BPT-14-W	2,800	15-3/4 X 7-3/4 <sup>1</sup>	31	12	24
	BPT-16-W	3,500	19-3/4 X 7-3/4 <sup>1</sup>	31	12	24
	BPT-18-W	5,000	*19-3/4 X 13-3/4 <sup>1</sup>	28	18	33
	BPT-20-W	6,500	*22-3/4 X 13-3/4 <sup>1</sup>	34	18	33
	BPT-24-W	10,000	39-3/4 x 15-3/4 <sup>2</sup>	42	18	33

\* Inlet and outlet collars are undersized 1/4" for flex or spiral duct. Allow 1/2" pipe diameters minimum straight duct inlet on all units.

1 Oval Inlet      2 Rectangular Inlet

### CONTROLS

- Factory Furnished       By Others  
 Normally Open       Normally Closed  
 Pressure Dependent       Pressure Independent

### THERMOSTAT

- Factory Furnished       By Others

### HOT WATER VALVE

- Factory Furnished       By Others