

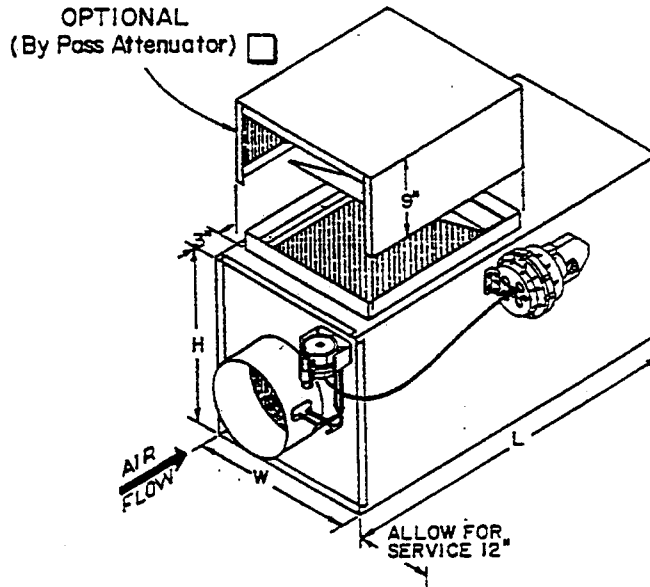

AIR ZONE INDUSTRIES, INC.

SERIES: BPT - PNEUMATIC

SUBMITTAL DATA



SPECIFICATIONS

CASING — Minimum 24 gauge galvanized steel reinforced for maximum rigidity and minimum leakage. Units complete with a minimum of 1/2" - 2# density insulation in accordance with NFPA-90A.

PRIMARY AIR VALVE — Constructed of welded steel channel frame with 18 gauge galvanized steel blades, die formed stiffeners and full blade stop. Stainless steel side seals standard along with blade seals to minimize leakage. All hardware is zinc plated with brass pivot points and bronze oilite bearings. Shafts are corrosion resistant 1/2" diameter.

DIMENSIONS

Qty.	Model	Max. CFM	Inlet Size	W	H	L
	BPT-04	200	3-3/4	11	12	24
	BPT-05	400	4-3/4	11	12	24
	BPT-06	550	5-3/4	11	12	24
	BPT-08	1,000	7-3/4	18	12	24
	BPT-10	1,600	10-3/4 X 7-3/4 ¹	18	12	24
	BPT-12	2,200	13-3/4 X 7-3/4 ¹	18	12	24
	BPT-14	2,800	15-3/4 X 7-3/4 ¹	31	12	24
	BPT-16	3,500	19-3/4 X 7-3/4 ¹	31	12	24
	BPT-18	5,000	*19-3/4 X 13-3/4 ¹	28	18	33
	BPT-20	6,500	*22-3/4 X 13-3/4 ¹	34	18	33
	BPT-24	10,000	39-3/4 x 15-3/4 ²	42	18	33

* Inlet and outlet collars are undersized 1/4" for flex or spiral duct. Allow 1 1/2" pipe diameters minimum straight duct inlet on all units.

1 Oval Inlet 2 Rectangular Inlet

CONTROLS

- Factory Mounted and Tested Field Mounted
 Normally Open Normally Closed
 Pressure Dependent Pressure Independent

THERMOSTAT

- Factory Furnished By Others